

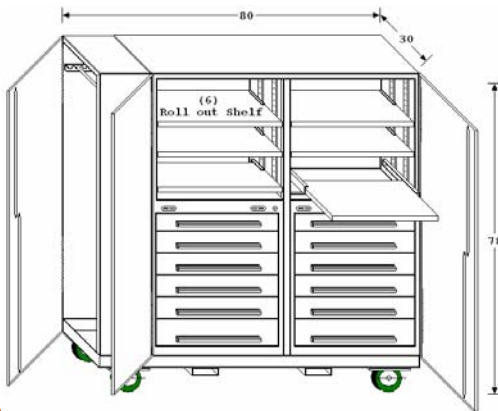

## FROM CONCEPT TO REALITY

### MOBILE TOOL/CHAIN MAINTENANCE CABINET

- 450# capacity drawers
- 450# capacity roll-out shelves (latch in/out)
- Slam latches for positive drawer locking
- Heavy duty fork pockets
- Adjustable chain rods
- Positive locking double doors



#### AVAILABLE OPTIONS:

- Pneumatic/electric hose reel
- Electrical receptacle
- Drawer layouts
- Rubber matting
- Custom colors
- Custom configurations
- Custom casters
- Custom sizes

**SPECIALTY PRODUCTS**

**SPECIALTY PRODUCTS**

**SPECIALTY PRODUCTS**